

CONCEPT MODELS

<http://www.con-sys.com//Index.htm>
email:concent models@con-svs.com

8331 Sheep Ranch Rd.
Mountain Ranch, CA 95246

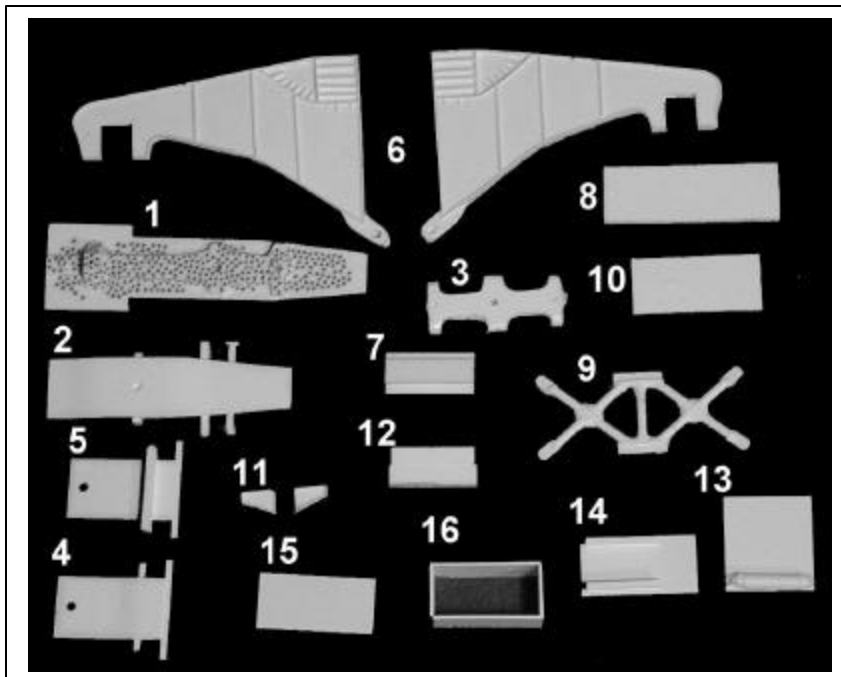

NOTE: This kit consists of resin castings and must be assembled with an ACC cement (not provided) – both the thicker types as well as the thin. Solvent cements will **NOT** bond the parts together! Resin parts are more fragile than common styrene plastic used in injection molded models. Use reasonable care in handling and do not apply any solvents.

CEBX 101 SCHNABEL CAR KIT

Item No.	PART DESCRIPTION	QTY.
1	Main Span Bolsters Bottom	2
2	Main Span Bolster Top	2
3	Center Span Bogie	2
4	Yoke - top	2
5	Yoke - bottom	2
6	Main Lift Girder Pair	2pr
7	Traverse Guide	2
8	Girder face plate	2
9	Girder Diagonal braces	2
10	Girder brace Bottom	2
11	Side supports pairs	2pr
12	Traverse Bearing	2
13	Deck with Tank	2
14	Equipment Cabinet Support	2
15	Equipment Cabinet Roof	2
16	Equipment Cabinet Sides	2
17	1-3/16" x 1/8" Plastic Tube	2
18	1-3/8" x 1/8" Plastic Tube	2
19	18" I.D. Washer (spacers)	2
20	2-56 x 3/16 screw	2
21	2-56 x 3/8" screw	8
22	Brake Stand	2
23	Brake Wheel	2
24	Decals	1
25	Instructions	1
26	Load Spacer Set	2
27	1/4" x 1/8" dia. Tube	2
28	Link Halves (Empty Car Connection)	2
29	Coupler Pocket Covers	2
30	1/8" x 2-56 Pan Hd. Screws	2
31	Pins, small	2

WARNING

Some parts have lead encapsulated within them. In the event the lead is exposed for any reason, do not allow it to remain on the skin. Dispose of any lead shavings that may result. Obey all safety precautions of all suggested cements and assembly materials.

Gluing with ACC Cements – USE WITH CARE

ACC cements allow the modeler to work very quickly. A general rule is to use the thin cements to glue long joints taking advantage of capillary action that makes the cement run the length of the seam. The thicker cement is suited to applying large area parts to each other. An accelerator can be applied sparingly. One technique is to apply the glue to one part and the accelerator to the other part to be joined. I also use a Q-tip to apply a minute amount of accelerator to the glue after the parts have been joined. The accelerator triggers the ACC cement to set very quickly. It is only slightly slower with the thicker cement. Work very carefully when positioning the parts for gluing. ACC cements adhere very quickly and permanently

Instructions

Tools Required

All basic model workers tools – files, motor-tool with fine burrs, hobby knife, 1/8" drill, Wood blocks for holding parts square, metal square, etc. Squadron's "Green Putty" or "Bondo" are needed for filler. Any ACC cement ("Krazy Glue"). ACC cement accelerator is also a good idea.

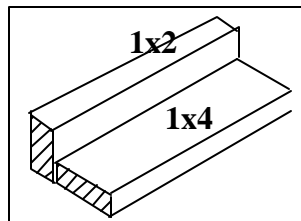

A gluing fixture is a great aid to assembly. It helps hold parts square while gluing.

PREPARATION Wash the parts before assembling with a dish washing detergent such as "Dawn". Rub lightly with a soft sponge.

ASSEMBLY

Bogie Assemblies - Make Two

1 Start by assembling the yokes by using a brass 1/8" guide pin as shown. The holes should be reamed with a 1/8" drill to allow the yoke to pivot freely on the shaft.

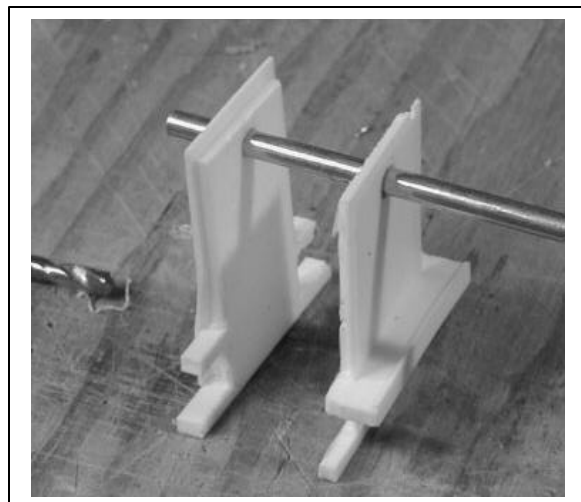

2 Apply ACC cement to glue the yoke halves as shown.

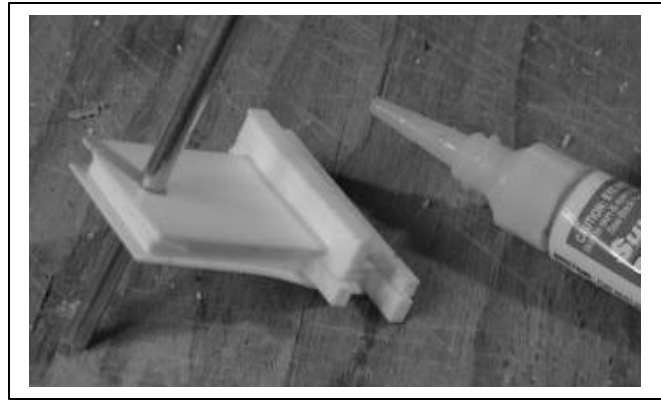

3 Ream the holes on the top and bottom main span bolster and thread onto a 1/8" guide rod.

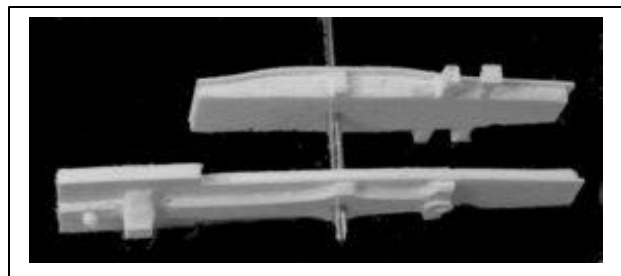

4 Apply ACC cement and press the top and bottom pieces together.

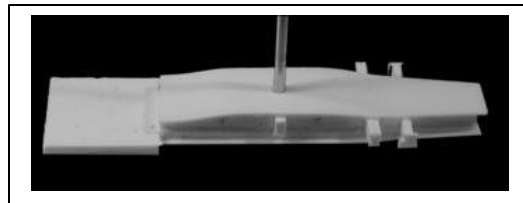

5 Add the 1/8" tube by cementing from the bottom of the bolster with ACC cement. Do not get any cement on the tube at the top side - or it will interfere with the yoke.



6 Apply the coupler cover with the 2-56 x 3/16" screw. Couplers will be installed after painting.

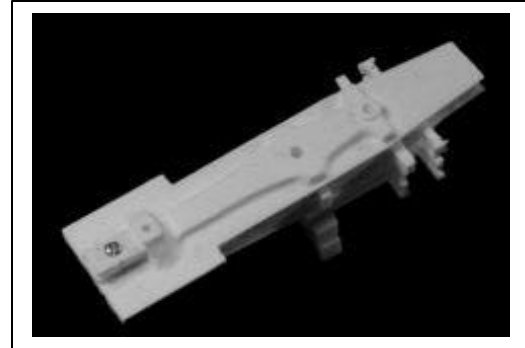

7 Add a 1/8" I.D. washer. Optionally this washer may be installed under the yoke if more clearance is desired.

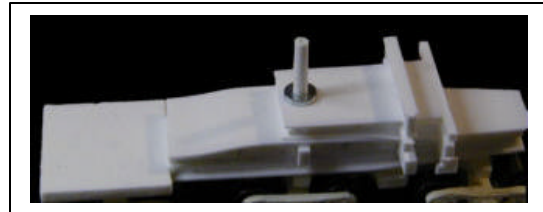

8 Cement the side supports to the center of the main span bolster. The flanged edges face outward. A small glue guide protrudes at the center location. Make sure that these are

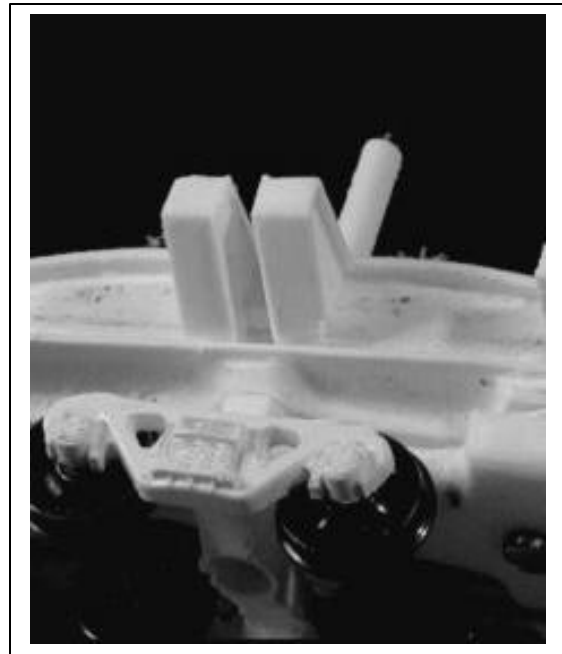

**Main Lift Girder
Assemblies - make 2**

1 Install a 1/8" brass guide rod for alignment purposes in the following steps. Fit Traverse Guide into the Main Lift girder pair as show. Do not glue yet. With the girder pair placed on a flat surface as shown, glue the girder face plate into place keeping the assembly square.

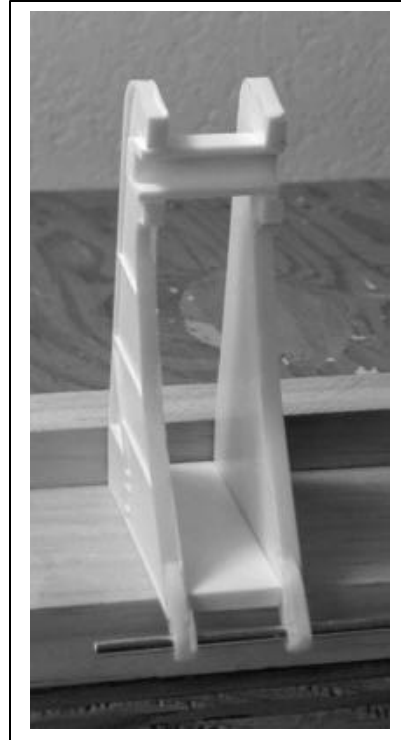

2 Install and glue the bottom girder brace as shown. This will establish the width of the girder and hold it square. Now glue the Traverse Guide into place.

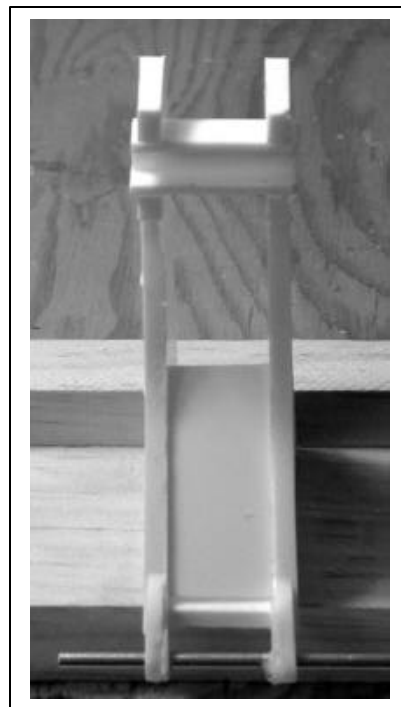

3 Trim one of the main girder diagonal braces as shown to allow it to fit in the space of the main girder. See the next two steps for clarification of this requirement.

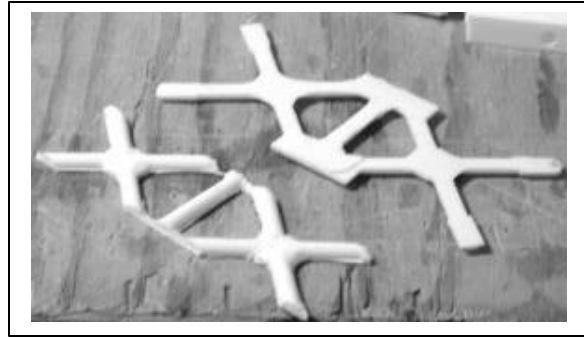

4 Glue the trimmed brace and a complete one as shown.

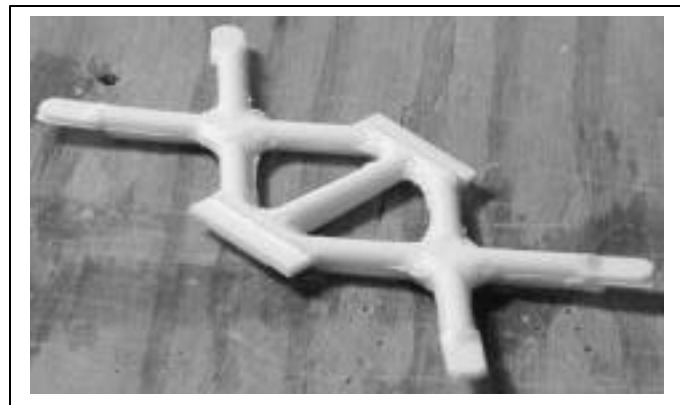

5 Install the diagonal brace assembly as shown with ACC cement.



Final Assembly

1 Install trucks (not provided in this kit) on the center span bolster and attach to the main span bolster. Install the third truck at the end.

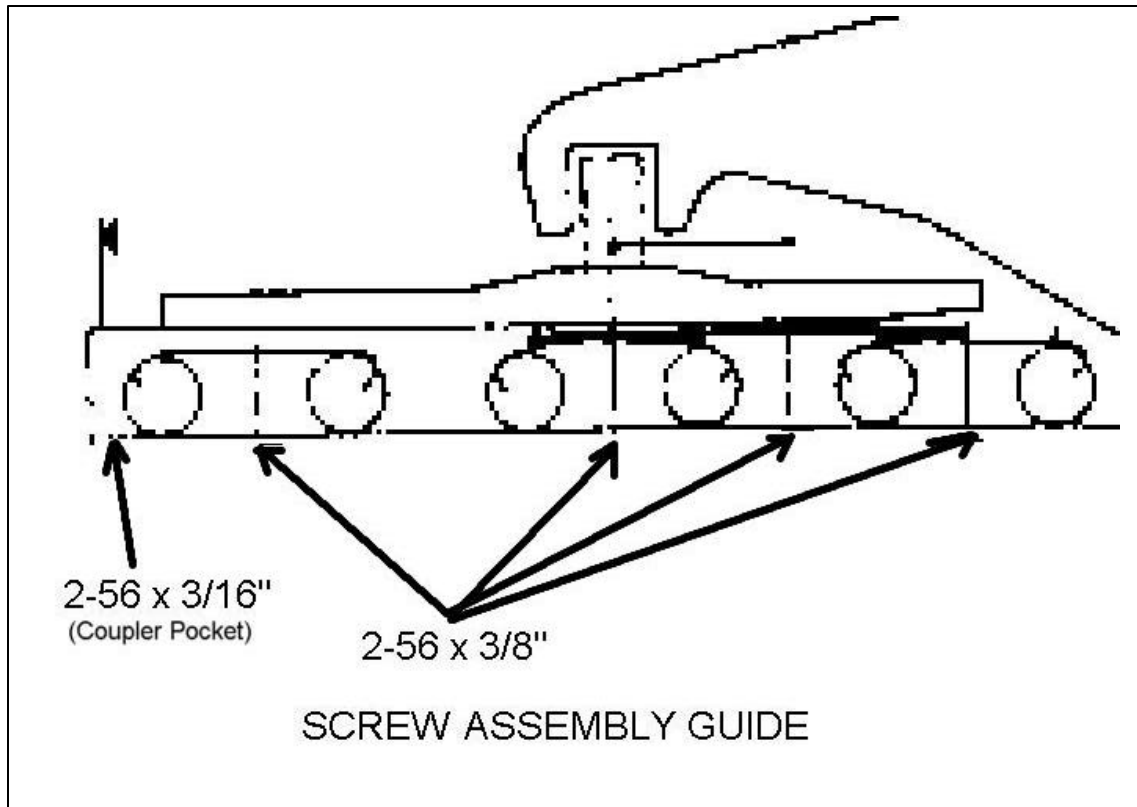
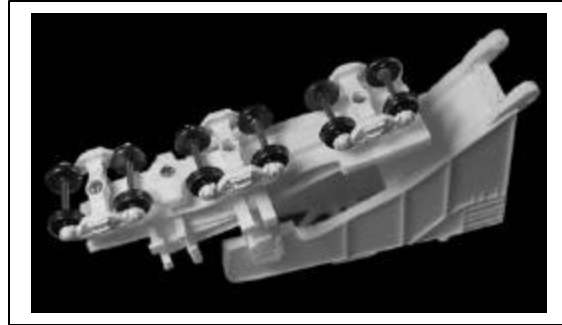

2 Install the deck with the tank.
Center on the bolster platform.

Add the equipment cabinet support as shown. It is off center and positioned on the left facing the end of the car.

Add the equipment cabinet and roof as shown. **DO NOT GLUE THE CABINET TO THE BASE UNTIL AFTER PAINTING.**

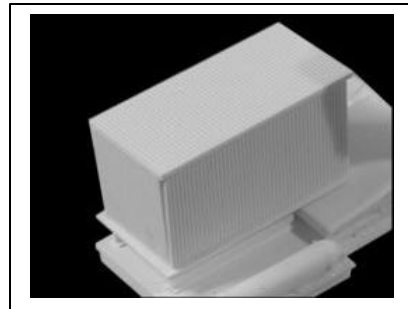
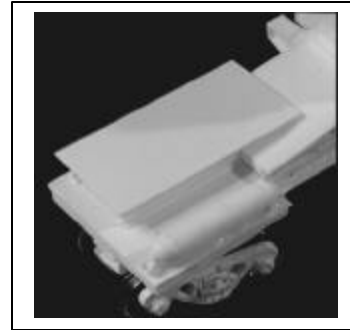
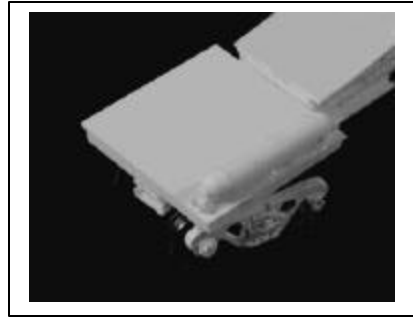

LOAD SPACER

1 Glue the load spacer parts together as shown. Add the 1/4" x 1/8" dia. tube as shown. The parts are attached to the face of the main girders when running the car empty. Drill a 1/8" hole in the face of the main girders. These parts are centered where all the little supports terminate at the top of the main girders.

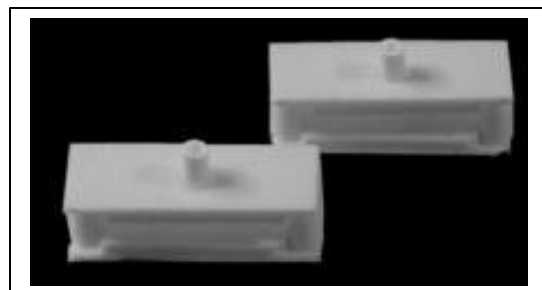
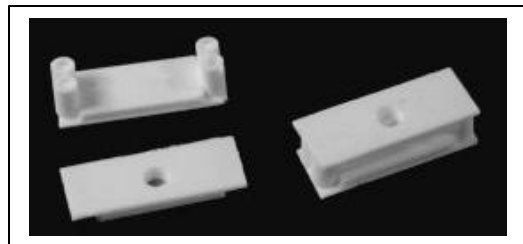

LINK - The link for connecting the empty halves of the car is trimmed and assembled from the two halves as shown. With the load girders upside down and held together in a straight line, mark one of the link halves as shown. Glue the two halves together at the line and trim.

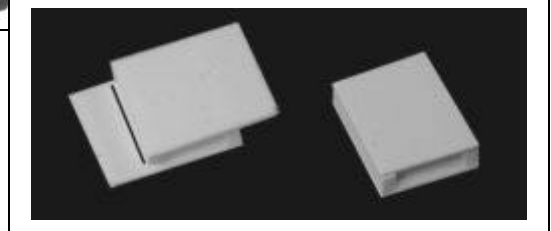
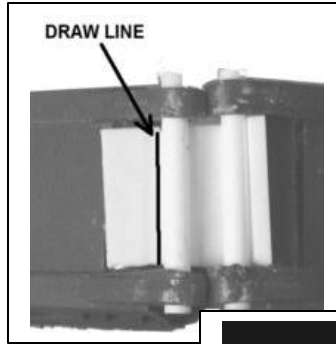

PAINING

After cleaning the surface as indicated in the initial instructions and cleaning up any blemishes, spray with a primer such as Floquil's. The lift girders, traverse support and yokes are painted red. The main and center bolster are painted black.

DECALING

The decals supplied are limited to the legible lettering derived from various photos. We are unable to find a suitable source for additional

