

CONCEPT MODELS

<http://www.con-sys.com/Index.htm>

8331 Sheep Ranch Rd.
Mountain Ranch, CA 95246

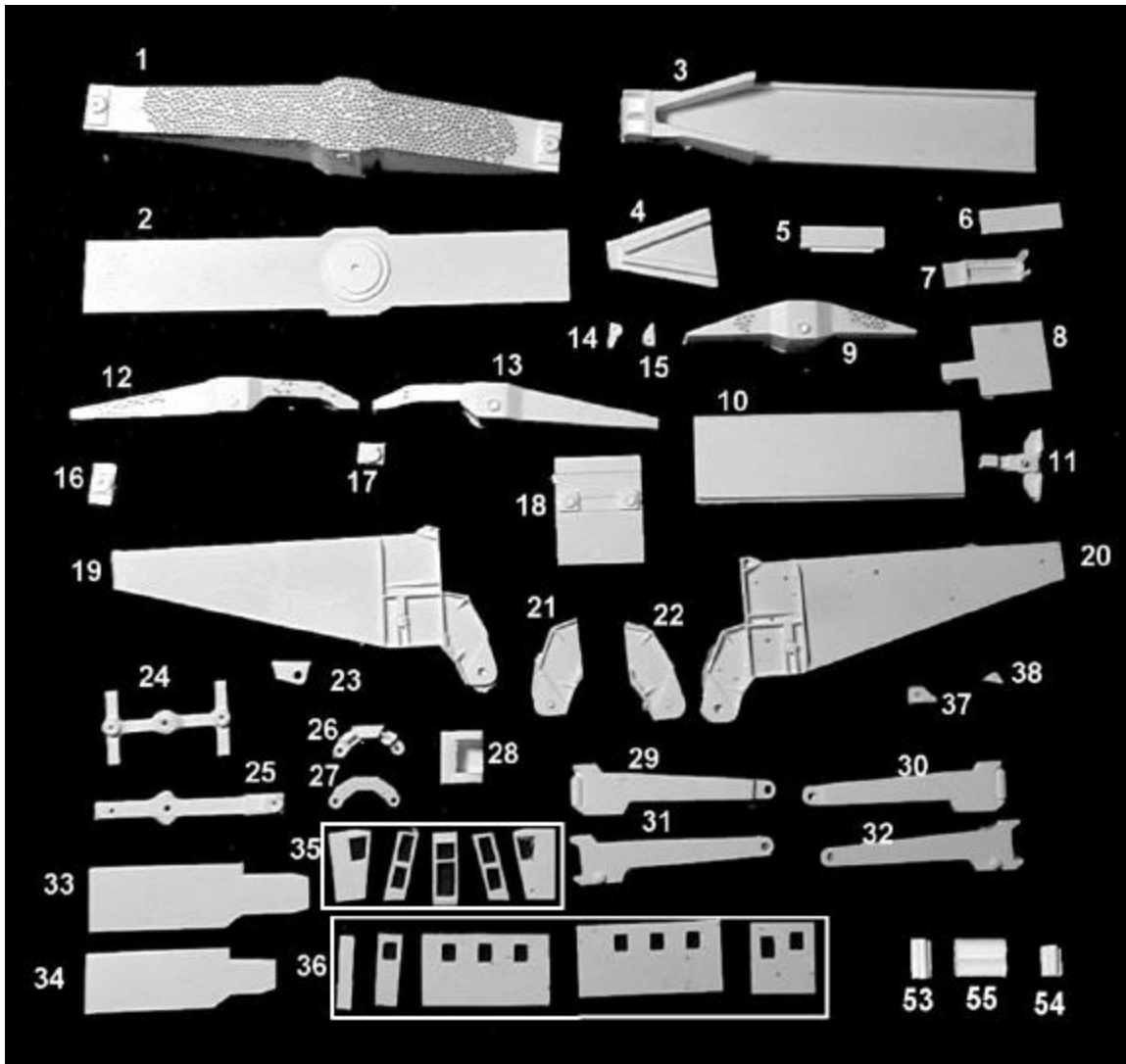

COMBUSTION ENGINEERING
CEBX 800 SCHNABEL CAR KIT

Standard Tools

All basic model workers tools – files, motor-tool with fine burrs, hobby knife, 1/8" drill, Wood blocks for holding parts square, metal square, etc.

Additional Tools

#50 Drill - Tap drill for 2-56 screws
 #44 Drill - Clear Drill for 2-56 screws
 #76 Drill - Pilot holes for pins
 2-56 tap - for creating threads for 2-56 screws
 3/32" drill - reaming 3/32" holes
 2 pcs 3/32" brass rod ~3/4" long
 1 piece 1/8" brass rod ~ 3" long

A gluing fixture is a great aid to assembly. It helps hold parts square while gluing.

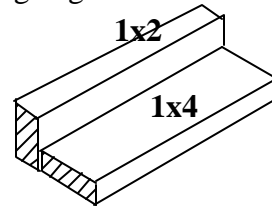

Instructions

NOTE: This kit consists of resin castings and must be assembled with an ACC cement (not provided) – both the thicker types as well as the thin. Solvent cements will **NOT** bond the parts together! Resin parts are more fragile than common styrene plastic used in injection molded models. Use reasonable care in handling and do not apply any solvents. The illustrations at the front show the general layout of parts for the car. Work very carefully when positioning the parts for gluing. ACC cements adhere very quickly and permanently.

Gluing with ACC Cements – USE WITH CARE

ACC cements allow the modeler to work very quickly. A general rule is to use the thin cements to glue long joints taking advantage of capillary action that makes the cement run the length of the seam. The thicker cement is suited to applying large area parts to each other. An accelerator can be applied sparingly. One technique is to apply the glue to one part and the accelerator to the other part to be joined. I also use a Q-tip to apply a minute amount of accelerator to the glue after the parts have been joined. The accelerator triggers the ACC cement to set very quickly. It is only slightly slower with the thicker cement.

WARNING! - POTENTIAL LEAD HAZARD

Some parts have lead encapsulated within them. In the event the lead is exposed for any reason, do not allow it to remain on the skin. Dispose of any lead shavings that may result. Obey all safety precautions of all suggested cements and assembly materials.

PARTS LIST

PACKING LIST FOR 1/2 OF CEBX 800 CAR

Item No.	DESCRIPTION	QTY.
1	Main Span Bolster	1
2	Main Span Bolster Deck	1
3	Main Lift Girder Top	1
4	Main Lift Girder Bottom Web	1
5	Main Girder Top Filler	1
6	Catwalk Deck	1
7	Catwalk	1
8	End Deck	1
9	Rear Span Bolster 1/2	2
10	Main Lift Girder Bottom	1
11	End Coupler Assy.	1
12	Front Span Bolster - rt. Half	1
13	Front Span Bolster - left half	1
14	Small Bolster Lift Ring	8
15	Main Span Bolster Lift Ring	2
16	Bogie Mount - large	3
17	Bogie Mount - small	1
18	Main Lift Girder Face Plate	1
19	Main Lift Girder - right	1
20	Main Lift Girder - left	1
21	Girder Lift Interior - right	1
22	Girder Lift Interior - left	1
23	Girder Arm Bracket	2
24	Truck Bogie	4
25	Front Truck Bogie	1
26	Yoke	1
27	Yoke Cover	1
28	Pedestal Block	1
29	Right Interior Arm	1
30	Left Interior Arm	1
31	Right Exterior Arm	1
32	Left Exterior Arm	1
33	Cab Roof	1
34	Cab Floor	1
35	Cab Front Window Group	1
36	Cab Sides Group	1
37	Hyd. Mount	2
38	Tie Downs	2
39	Hyd. Ram	2

Cont.

Item No.	DESCRIPTION	QTY.
41	Coupler Pocket Cover	1
42	1/8" 2-56 Screw	1
43	3/8" 2-56 Screw	10
44	1/2" 2-56 Screw	7
45	3/32" Tube x 1 Scale Foot	4
46	1/8" Tube x 1'9" Scale Feet	2
47	1/8" Tube x 6 Scale feet	1
48	Pins, Small	3
49	Pins, Large	2
50	Brake Reservoir	1
51	Brake Wheel	1
52	Brake Cylinder	1
53	Hyd. Pivot, Large	1
54	Hyd. Pivot, Small	1
55	Hyd. Lift Cyl.	1
56	Front Bolster Lift Arm Kit (4 pcs.)	1
57	Brake Stand	1
58	Hydraulic Accumulator Tank	1
-	Decals	1
-	Instructions	1

CAUTION: Wash the parts before assembling with a dish washing detergent such as "Dawn". Rub lightly with a soft sponge. Use a lacquer based primer such as floquil.

Rear Span Bolster

1 Place 2 halves of the rear span bolster (9) on supports to insure the bottom ends will be even.



2 After filing away any flash at the seam, install the truck mount pads (16) at the ends of the bolster exactly centered on the seam. Drill and tap the pads for a 2-56 screw being careful not to drill all the way through the bolster.

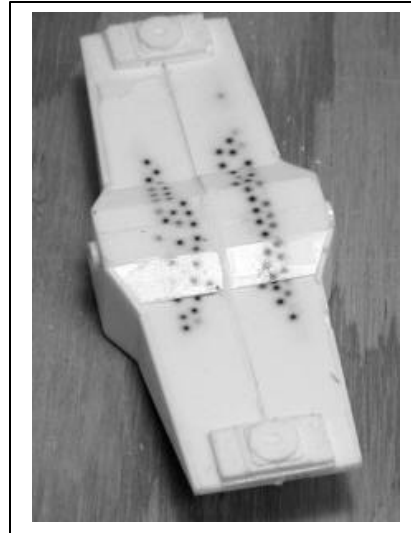

3 Mount the catwalk (7) by filing the legs to the proper angle. The catwalk is mounted on the left rear panel as shown. Attach the diamond plate decking (6) to the top side of the catwalk.

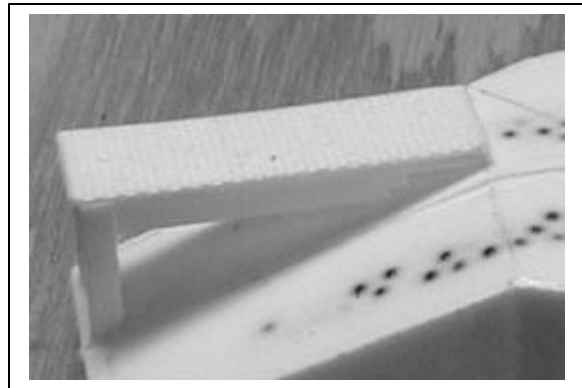

4 File a bevel on the brake reservoir (50) to make it level and mount. Likewise file a bevel on the brake valve base (51) and mount tucked under the catwalk as shown. Next, attach the Hydraulic Accumulator Tank (58) under the catwalk as shown.

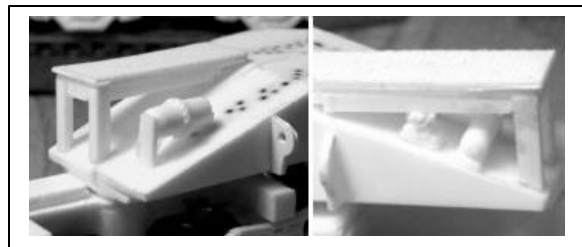

Front Span Bolster

1 Remove any flash by filing and assemble the two halves of the Front Span Bolster (12,13) with ACC cement making sure the two halves are on a flat, even surface.



2 Attach a large bogie mount (16) to the rear of the bolster. Attach a small bogie mount (17) to the front of the bolster. Make sure both are flat in relation to the top surface. Drill and tap for 2-56 being careful not to drill all the way through. Cut the head off of a 3/8" 2-56 screw. After rounding the cut off end, insert the other end into the small bogie mount.



3 Add the front bolster lift arm (56) to each side of the narrow end. The part is already beveled to make the arm extend straight from the bolster. Add a small lift ring under the arm with the large end outboard.

Lift Ring Locations

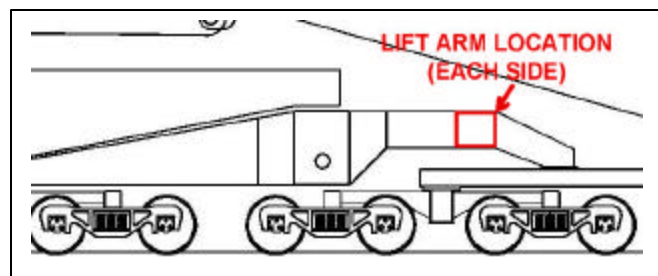
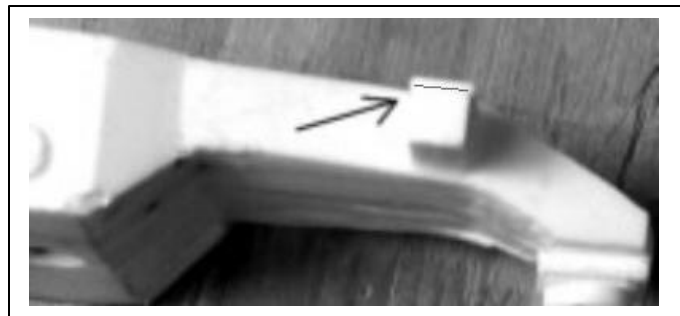
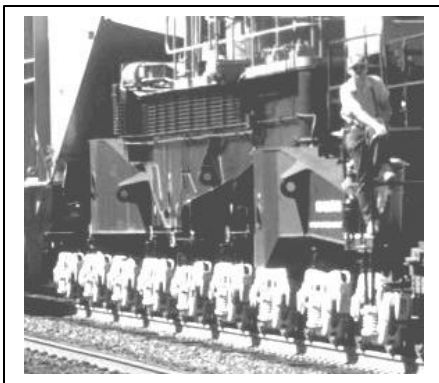

Main Span Bolster

1 Mount the Main Span Bolster Deck (2) centered on the Main Span Bolster (1). The ears on the deck should match shape of the bolster. The pivot circles will be on top.



2 Mark two lines across the short end of the bolster. One line 1" from the end and another 3/16". Mark 1/8" from the sides as shown.

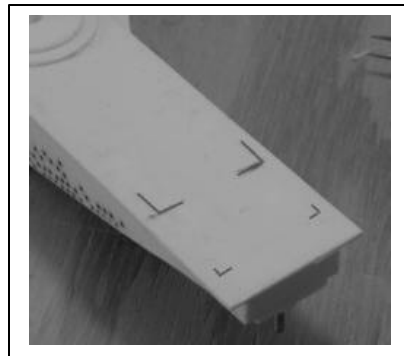

3 Drill a 76 hole 1/32" from the end inside the Hydraulic Mount (37) as shown.

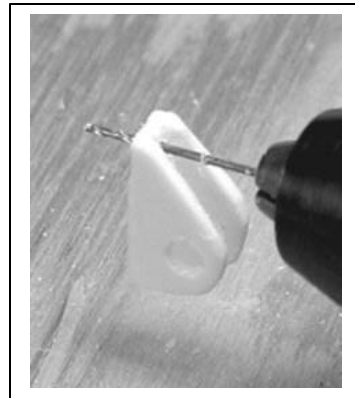

4 Use the Hydraulic Mount as a guide and continue drilling into the bolster and mount the Hyd. Mount with a small pin as shown. The pin will have to be trimmed.

Drill a 1/8" hole in the center of the bolster deck perpendicular to the top surface. Drill ~1/4" deep and insert the 1/8" x 6' tube (47).

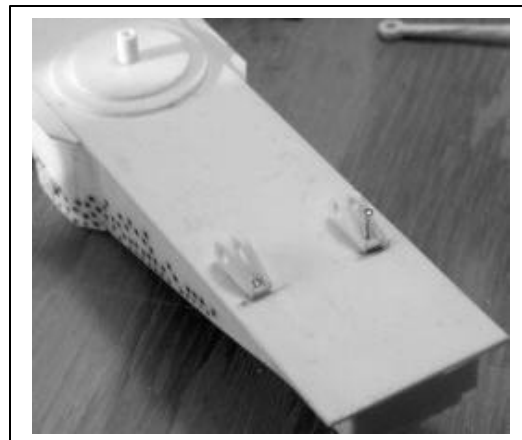

5 Mount the tie downs (38) as shown.

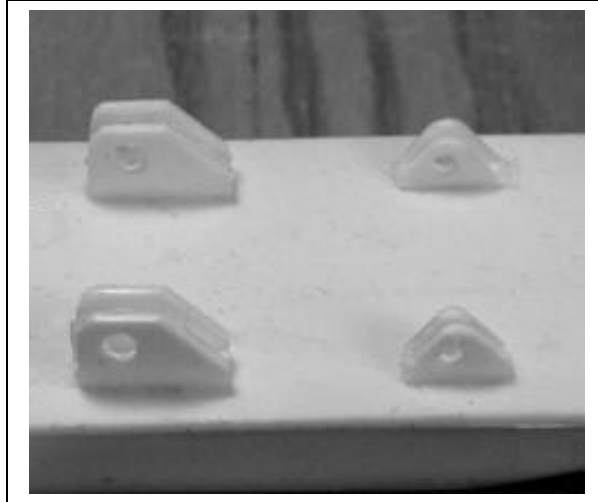

Pedestal Arm

1 Use the #76 drill to drill the Pedestal Arm (29,30,31,32) pivots points.



2 With the Pedestal Block (28) and arm upside down. Match up one pedestal arm even with the bottom, centered. Using the previously made hole in the pedestal arm, drill into the pedestal block. Cut one of the long pins to 1/2" and install by **LIGHTLY** tapping with a hammer.



3 Use a 1/8" brass rod, align the other pedestal arm and repeat the above process



4 Use 3/32" brass rods to align the yoke assembly (26,27) for gluing. Be careful to not get any glue on the rods or holes.



5 Install the Hydraulic Rams (39) using 3/32" plastic tubes.

6 Glue the yoke assembly to the pedestal block as shown. The yoke should be flush with the bottom.

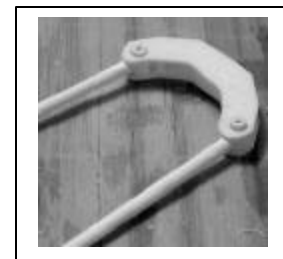
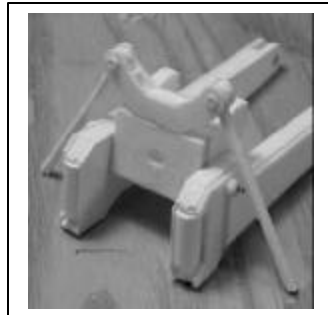

Main Lift Arm Girders

1 Attach the web shape piece (4) to the bottom of the Main Lift Girder Top (3). Then, attach one side (19,20). Make sure it is square.



2 Attach the other side again making sure it is glued square and even with the other side.

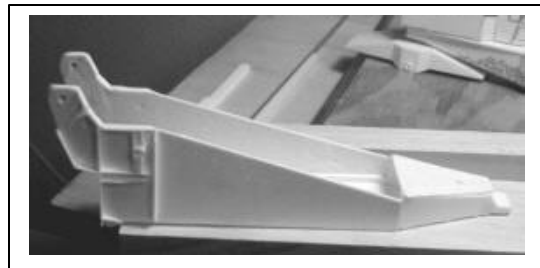

3 Thread the sides and girder lift interiors (21,22) through a 1/8" brass rod for alignment. Apply ACC cement and fit the interiors to the sides.

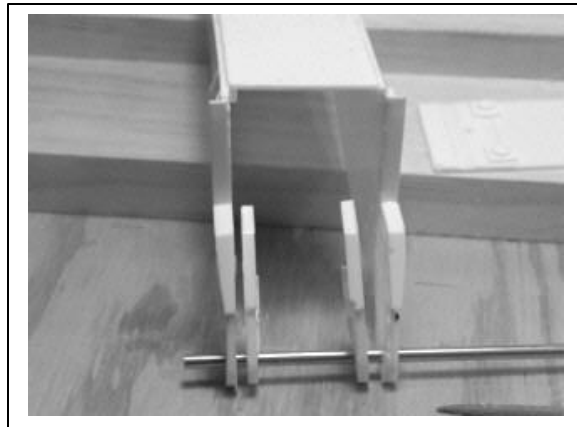

4 Insert the Main Girder Face Plate (18) aligning it with the bottom edge of the girder sides.



5 Install the small top filler (5) by first filing a bevel on the small lip that will extend under the girder top. File to fit so that the other edge tucks behind the girder face.



6 After filing the interior lift arms (21,22) to admit the Girder Arm Bracket (23), Thread the parts with a 1/8" brass rod as shown. The Girder arm brackets are positioned so that the holes are closest to the pedestal arms. The attachment is made with the bracket aligned with the end of the girder bottom (10).

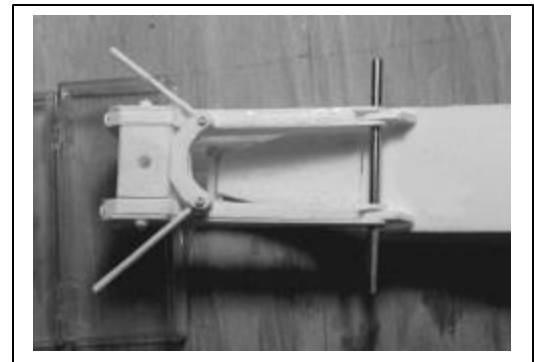

7 Glue the brackets (23) to the bottom (10) making sure that the assembly is straight and does not "dog leg" since this will unbalance the car.

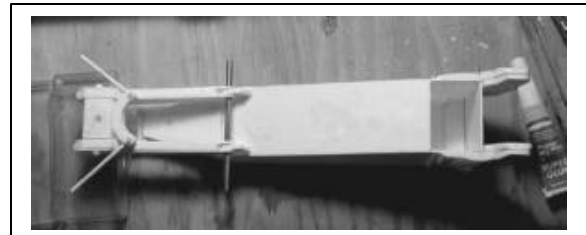

8 There is a small bracket at the top of the assembly that can be drilled for a .035" or .032" rod (not supplied) that extends between the two sides positioned above the girder face.

9 Layout parts 53,54, & 55 as shown.
This is the hydraulic lift cylinder assembly.
Notice the pivots that fit over then cylinder ends are different sizes.



10 Cement the parts together as shown.

NOTE: The following step may be delayed until all parts have been assembled and painted. It is shown here since it is a part of the main girder assembly.

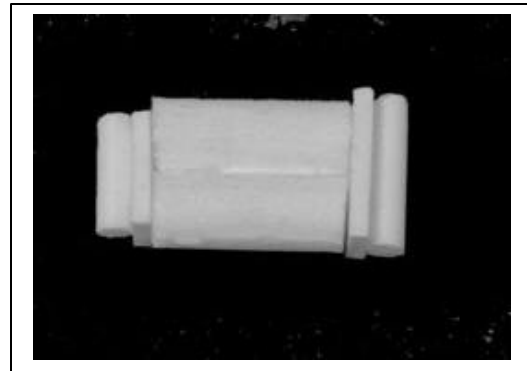

11 The hydraulic lift assembly is installed between the pedestal block and the main lift girder assembly. The small pivot faces downward into the pedestal block. This assembly may propped into place since the weight of the main lift girder will hold it into place. If the model is run on a layout it may be better to use a resilient glue such as "QUIK GRIP" from Wal-Mart's hobby & craft department.

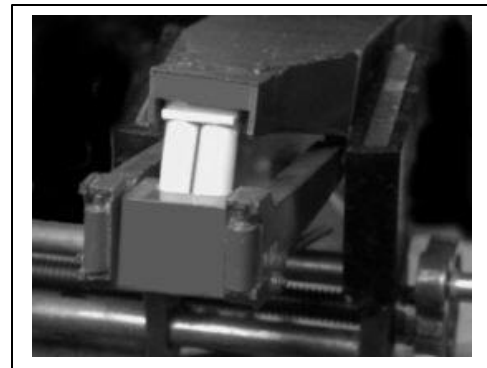

Operator's Cab

1 Attach the sides to the floor (34) (shorter than the roof) just even with the end of the floor. The end will overlap the sides. Note one of the sides is longer.

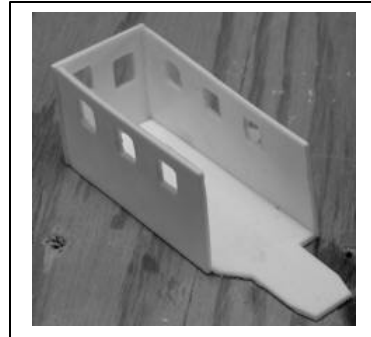

2 Attach the left side of the narrowed cab. Make sure this is straight - perpendicular to the floor



3 Attach the right side of the narrowed cab. Also attach the small spacer wall between the left side and the narrowed left side. The piece goes inside the cab. Trim it even with the other sides.

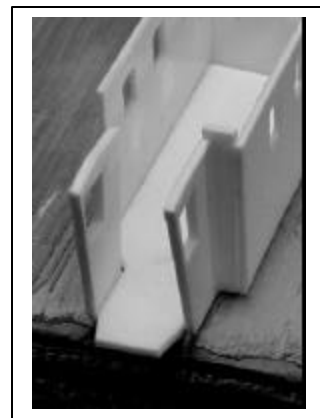

4 Attach the angled widows to the corners of the narrowed cab.

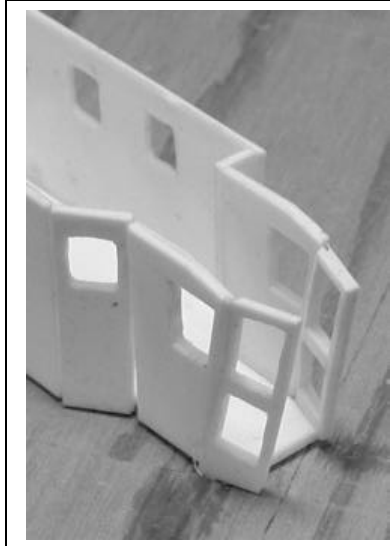

5 Attach the front window to the narrowed cab.

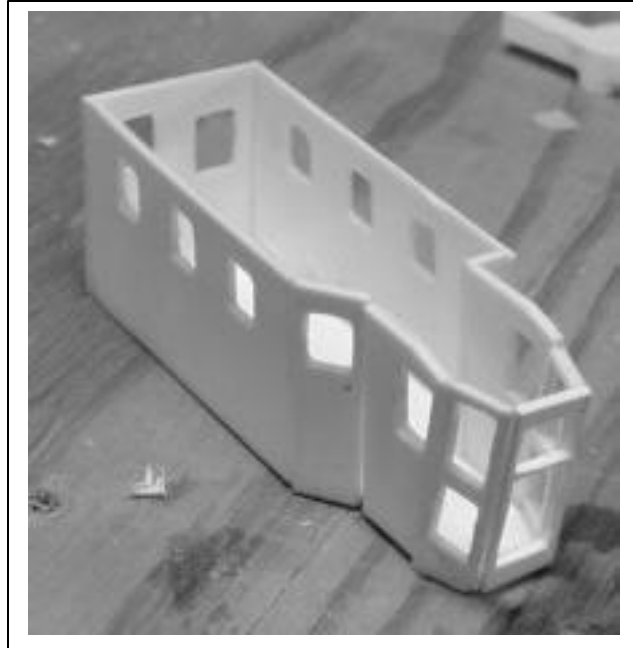

6 After filing down the windowed area and filling any gaps with putty or cement, fit the roof to the cab. Break the roof at the scribe mark, file a slight bevel and glue at the same angle as the front sides. Now shorten the roof so that the roof will be flush with the sides. Glue the roof to the top of the cab and file all sides flush.

7 In order to gain access to the interior of the cab after painting, drill out the floor except for a narrow lip around all edges. The cab will be painted before attaching to the main bolster. Set aside.

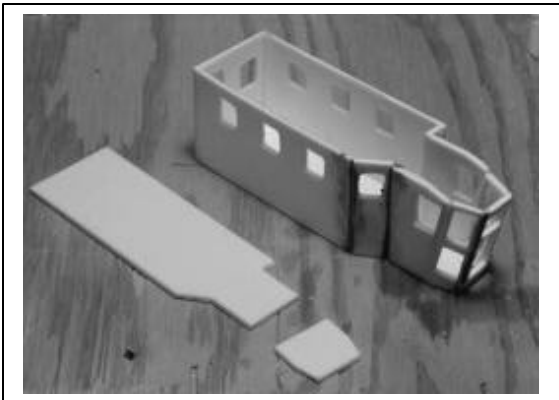

Truck Assemblies

1 The end deck (8) must be installed on one of the truck bogies. Prepare the end deck by attaching end coupler assy. (11) to the deck as shown. Note the position of the deck extension that leads to the catwalk on the rear span bolster.

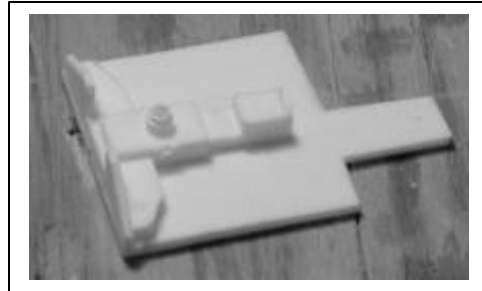

2 Attach the deck/draft gear assembly to one of the truck bogies. Make sure to cement the deck to the bogie as well as the frame member of the draft gear assembly.

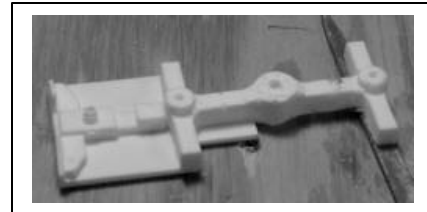

3 Use the 1/8" 2-56 screw to attach the draft gear cover to the assembly. The bogies, part 25 and 25, may be set aside for painting.

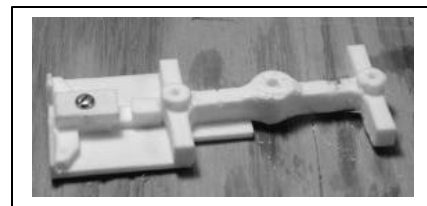

4 Brake stand and brake wheel are installed on the deck similar to the position found on most cabooses.

ASSEMBLY

Erecting would be more like it due to the immense size and weight of the components. Fit the assemblies together and check for clearances. The car was designed to permit operation on most model railroads and compromises have been made to this effect.

If you wish to run the car empty, make two connecting pieces by drilling two 1/8" holes in a sheet of .040" or .060" styrene. It will also be necessary to place a support between the compression pads (little buttons on the girder face).

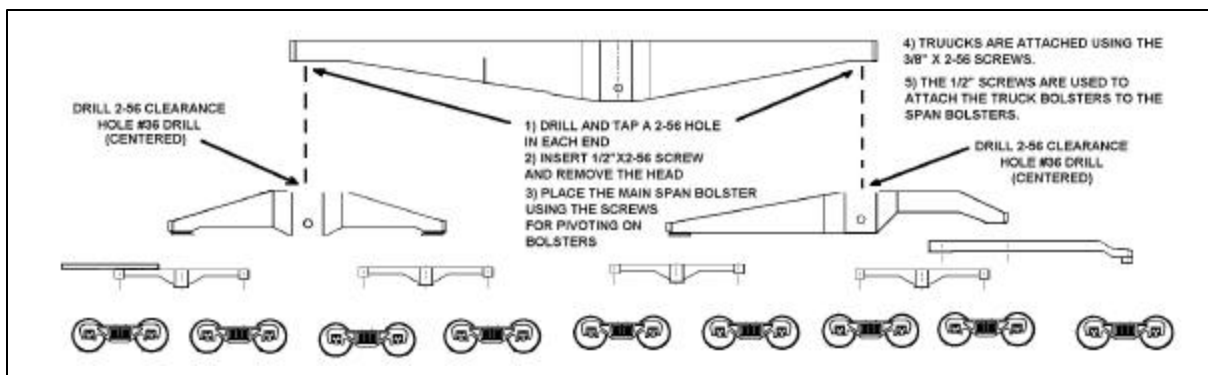

DECAL LAYOUT

